

## iSPAN® 36701 4G Wireless Base Station AMC

High Performance for Next Generation Wireless Access Networks

### APPLICATIONS

**LTE / WiMAX**

**Pico / Microcells**

**Enterprise Femtocells**

### FEATURES

AMC.0 R2.0 Mid Size or Full Size AdvancedMC

Mindspeed Transcende 4020 SoC

GE (AMC.2) plus PCIe (AMC.1) or sRIO to carrier

Front panel I/O options:

- SFP Modules for CPRI
- GE RJ45 Interface
- SMB micro-coaxial for GPS antenna/1PPS I/O signal input/output

Clocking/Timing options:

GPS Receiver/Clock Disciplining, IEEE1588 v2 and SyncE

Integrated L2 and L1 on a single SoC provides lowest possible latency

Scalable solutions by integrating multiple 36701s

Rich Ecosystem of software tools and applications available through Interphase iWARE® and Partner solutions



### Wireless Base Station on a Card

The iSPAN 36701 4G Wireless Base Station AdvancedMC™ (AMC) supports the complete functions of a wireless base station (with the exception of the radio) in a very small footprint. It is designed for use in 4G Networks including the LTE eNodeB as well as next generation WiMAX\* basestations. It features one or two Optical Interfaces on the front panel for CPRI Baseband interfaces and AMC connector support for a combination of Gigabit Ethernet, Serial RapidIO™, and PCI Express™ links.

### High Performance Platform - Multicore Processor and DSP

The iSPAN 36701 utilizes the Mindspeed Transcende™ 4000/4020 System on a Chip (SoC) with integrated support for the Radio Interface, DSPs for Baseband PHY processing, and ARM A9 cores for L2 / L3 Protocol Processing, as well as eNodeB software aligned with the latest 3GPP requirements:

- Supports the complete LTE Layers 1 and 2 processing needs for three 10MHz sectors 2x2 MIMO in one device (T4000) or one 20 MHz sector with 2x2 MIMO in one device (T4020)
- Backhaul and air interface security: support for AES, 3DES, HMAC, SNOW-3G, Kasumi
- High data throughput of FEC (greater than 400 Mbps)
- Large L1 DSP memory minimizes off-chip memory access
- Flexible Mindspeed Application Processor (MAP) supporting PAPR, G-RAKE and FFT algorithms
- Higher level precision on FFT (16,24)
- Lower power than competing solutions
- Optimized for picocell applications

### Accelerated Development / Lower cost of ownership

- PHY, L1/L2 Software and Hardware Reference Designs => "fast-start" development
- Common Platform for complete portfolio => Develop Picocell to Multi-sector Microcell solutions which can be reutilized in Macrocells as well.
- Mix of programmable DSP and H/W acceleration allows DSP headroom for additional customer feature development

### Road to 4G

The iSPAN 36701 is designed as an entry point for the development of next generation wireless microcell, picocell, and enterprise femtocell base stations. Interphase can adapt or extend this solution to meet your needs in AMC or in any other form factor required.



## iSPAN 36701 Wireless Base Station AMC

### External Interfaces

- 1 or 2 SFP receptacles for CPRI 4.1
- SMB micro-coaxial for GPS antenna/1PPS I/O signal input/output
- 1 or 2 10/100/1000 Ethernet ports
- 3 UART (USB)

### AdvancedMC Connectivity

- Gigabit Ethernet: AMC.2 Type E2, ports 0, 1 GE (shared with the front panel RJ45s)
- PCI Express: AMC.1 Type 4 PCIe on ports 4-7
- Serial Rapid IO: AMC.4 Type 4 sRIO on ports 4-7

### Processor

#### Mindspeed Transcende 4020 SoC

- 6 ARM Cortex A9 (RISC) Processor Cores @ 750 MHz (11250 DMIPS)
- Option to use T4000 @ 600 MHz
- 10 CEVA DSP Cores (24 GMAC/s)
- FEC Processor
- 10 Application Processors for FFT (6000 MIPS / 24 GMAC/s)
- 2 Security Coprocessors

### Memory

- 512MB DDR3 SDRAM expandable to 2GB with optional ECC
- 64MB Boot Flash
- 1 to 16GB Storage Flash

### Other

- GPS Receiver onboard (optional)
- Precision clock sourcing +/- 50PPB on board (optional)

### Software

- Complete Reference 3G UMTS\* and 4G PHY (LTE and WiMAX\*) Application including verification test bench
  - Executables, source code, object code, header files
  - Documentation on architecture, APIs and performance
  - Tools for software development, verification, and performance profiling
  - Development application for complete base station
  - Fully programmable software source code licenses are available
- Integrated Layer 2/3 eNodeB software protocol stacks for LTE
  - L2: MAC, RLC, PDCP, RRC
  - L3: S1AP, X2AP
  - Supports FDD mode as per Release 8 specifications
  - Bandwidth configuration up to 20MHz
  - 2x2 MIMO
- Additional elements of the eNodeB or WiMAX full base stations reference design software are available directly from our software partners or can be provided through Interphase eNodeB / WiMAX\* Application Software

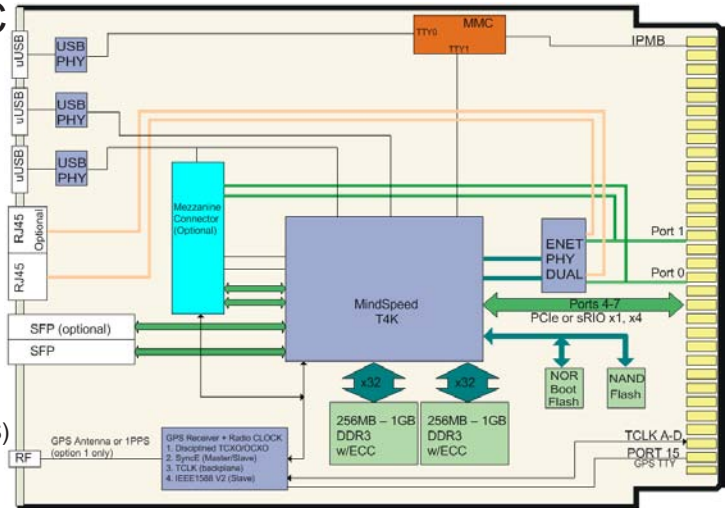

## Technical Specifications

### Architecture

Processor Transcende 4020 SoC  
Option to use T4000

### Memory

RAM 512MB DDR3 SDRAM  
Expandable to 2GB with optional ECC

Flash 64MB Boot Flash  
1 GB Storage Flash

### Mechanical

Form Factor AMC.0 R2.0 AdvancedMC  
Mid Size or Full Size, or to custom spec

Length 180.6 mm (7.11 in.)

Width 73.5 mm (2.89 in.) (single-width)

### Operating Environment

Power 26W Typical / 36W Max

Consumption

Temperature 0 to 55 °C (32 to 144.5 °F)

Storage Range -40 to 80 °C (-40 to 176 °F)

Relative Humidity 5% to 95% non-condensing

Altitude 0 to 2000 M (0 to 6500 ft)

7/11/11

### Corporate Headquarters

2901 N. Dallas Parkway  
Plano, Texas 75093  
1-800-327-8638  
Phone: + 1.214.654.5000  
Fax: + 1.214.654.5500



### About Interphase Corporation

Interphase Corporation (NASDAQ: INPH) delivers solutions for LTE and WiMAX, interworking gateways, packet processing, network connectivity, and security for key applications for the communications and enterprise markets. Founded in 1974, Interphase provides expert engineering design and electronics manufacturing services, in addition to its commercial-off-the-shelf (COTS) product portfolio. Interphase is headquartered in Plano, Texas, with sales offices in the United States and Europe.

© 2011 Interphase, iSPAN, and the Interphase logo are trademarks or registered trademarks of Interphase Corporation. All other trademarks are the property of their respective owners. Specifications and features subject to change without notice.