



iSPAN[®] 3640 AdvancedMC[™] High Performance T1/E1/J1 Controller

*Octal Port Multiprotocol Controller for SS7 and Media Applications on
AdvancedTCA and μ TCA Platforms*

FEATURES

Eight interfaces, individually software configurable as T1, E1 or J1

Optimized for SS7 and Media applications

Designed for ATCA and μ TCA platforms

Reliable and field-proven Software Development Suite (iWARE[®] SDS)

On-board support for multiple network protocols:

- SS7 (MTP1 & MTP2) LSL/HSL
- SAAL/GR-2878
- AAL5/ATM
- Monitoring
- TDM-to-IP Media Gateway*

Pre-integrated protocol layers with various 3rd party SS7 stacks

Single width, Mid-size or Full-size PICMG[™] AMC.0 R2.0 compliant

Front or Rear access

High-impedance mode interfaces for monitoring applications

Optional acceleration of media termination and circuit switching

Freescale[™] MPC8568 (PowerQUICC III[™] QUICC Engines[™]) processor

PCI-Express (AMC.1) and Gigabit Ethernet (AMC.2) connectivity

Support of telecom clocks TCLKA and TCLKB, and optionally TCLKC/D.

APPLICATIONS

Softswitches and MSC Servers

Serving / Gateway GPRS Support Nodes (xGSNs)

Signaling Gateways

Wireless BSCs/RNCs

Media Gateways

Media Servers

PBXs

HLRs

Designed for Signaling and Media Applications

The iSPAN 3640 AdvancedMC[™] High Performance T1/E1/J1 Communications Controller, together with the iWARE Software Development Suite, delivers a comprehensive high-capacity connectivity solution for use with AdvancedTCA and MicroTCA platforms to deliver a wide range of Voice-Over-IP, Wireless and IP Multi-Media Subsystem (IMS) infrastructure application elements.

High Performance and Capacity

Via its 8 T1/E1/J1 interfaces, the iSPAN 3640 supports up to 248 SS7 Low Speed Links, 8 High Speed Links, or 248 media channels, and thus optimizes the system slot usage. Thanks to its high-performance PCI-Express interface or its gigabit Ethernet connectivity to a host processor, the iSPAN 3640 enables rapid exchange of payload information and is hence ideal for a broad spectrum of signaling applications.

Powerful Solution Architecture

The iSPAN 3640 incorporates the last generation of Freescale PowerQUICC III[™] communications controller that enables this level of performance and capacity for highly demanding SS7 applications. With its FPGA-based TDM switching, enhanced raw data transfer mode to/from the host, and embedded TDM-to-IP Gateway function*, the iSPAN 3640 is also strongly designed for media applications.

With its high-impedance interfaces and monitoring mode of operation, the iSPAN 3640 is also the ideal platform for SS7 monitoring services applications.

(*) Future evolution



iSPAN 3640 Details

AdvancedMC Connectivity

- PCI-Express x4 links on AMC ports 4-7 (AMC.1 Type 4)
- 2 Gigabit Ethernet links on AMC ports 0-1 (AMC.2 Type E2)
- Option for x4 SRIO on AMC ports 8-11
- Telecom clocks on TCLKA, TCLKB, TCLKC and TCLKD
- PCI-Express 100 MHz clock input on AMC FCLKA
- T1/E1/J1 line signals on AMC port 20-12 towards 3rd-party Rear Transition Module

Processor/Memory

- PowerQUICC III™ (MPC8568) RISC processor, allowing full support of various communications protocols, and reducing host CPU processing
- FPGA-based TDM switching
- 512 MB of DDR2 SDRAM
- 256 MB downloadable 8-bit Flash Memory
- 64 MB of Boot Flash

Network Interfaces

The iSPAN 3640 can interface with PSTN/ISDN networks via:

- Eight interfaces individually software configurable in T1 (100Ω), E1 (120Ω) or J1 (110Ω) mode
 - Front access, on 4 RJ45 connectors, each supporting 2 lines, or
 - Rear access, on AMC ports 20 to 12
- Infineon OctalFALC™ framer supporting long or short haul interfaces, AMI, HDB3, or B8ZS line coding and various superframe formats
- Line interfaces configurable in high-impedance mode for monitoring
- Each line is individually configurable in LT (clock slave), NT (clock master) or Master/Master mode
- Support of independent clock rhythm on each T1/E1/J1 line
- One Red/Green dual-color LED per port

Telecom Clock Management

- Three synchronization modes:
 - Free running internal clock
 - Recovered clock (loop back timing) from any T1/E1/J1 line
 - System telecom clock reference (via AMC TCLKA or TCLKC)
- Clock can be forwarded to AMC TCLKB or TCLKD

Software

Interphase offers a robust suite of software development tools to help shorten the learning curve and design cycle for integration projects based on the iSPAN 3640 communications controller.

Board Development Kit

The iSPAN 3640 BDK is specific to this hardware and not tied to a particular operating system environment. The kit contains the following main components:

- Boot Firmware with power-on self-test (POST), power-on boot sequence, built-in self-test (BIST) and configuration via a command line interface
- Setup and Built-in Self-test utilities, documentation

iWARE® Software Development Suite (SDS)

The iWARE SDS is an integrated set of embedded firmware, APIs, host drivers and utilities that accelerates application development and eases integration of the iSPAN 3640 to deliver end applications.

It provides common APIs and software environment across all Interphase T1/E1 products, thus protecting the application developer's investments.

Protocols provided by iWARE SDS:

- SS7 MTP1/2 (up to 248 LSLs, 8 HSL) – ITU-T Q.703, ANSI T1.111.3, TTC JT-Q.703, NTT Q.703, HSL ITU-T Q.703 Annex A and China YD/T 1125
- SSCF and SSCOP (SAAL) – ITU-T Q.2130 (UNI), Q.2140 (NNI), Q.2110, GE-2878-CORE
- ATM AAL5 (SAR) – ITU-T I.361, I.362, I.363.5, ATM Forum UNI
- Raw (n*64K) and Enhanced media transfers (for HMP applications)
- Monitoring mode with event filtering and time-stamping
- TDM-to-RTP conversion for media transport over IP backplane (future evolution)

iWARE SDS provides the same API in PCI-Express and Ethernet modes.

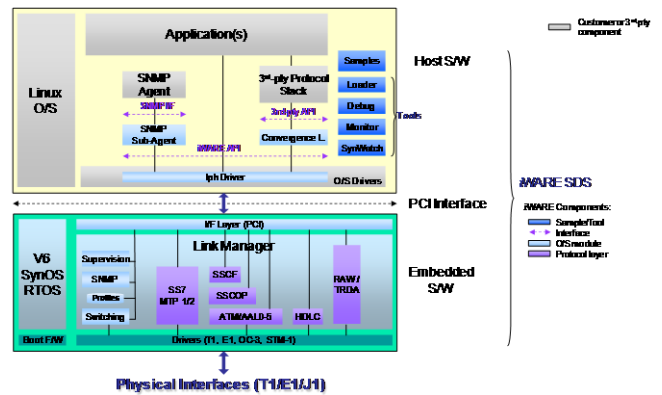

Technical Specifications	
Architecture	
Processor	MPC8568
RAM Memory	512 MB DDR2 SDRAM
ROM Memory	256 MB Firmware Flash, 64 MB Boot Flash
Connectivity	AMC.1 (PCI Express), AMC.2 (Ethernet)
Mechanical	
Form Factor	AdvancedMC single-width Full/Mid-size
Length	180.6 mm (7.11 in.)
Width	73.5 mm (2.89 in.) (single-width)
Operating Environment	
Power Consumption	30 W @ 12 V, 0.2 W @ 3.3 V
Temperature	0 to 55 °C (32 to 131 °F)
Storage Range	-40 to 80 °C (-40 to 176 °F)
Relative Humidity	5% to 95% non-condensing
Altitude	0 to 15,000 ft

Corporate Headquarters

2901 N. Dallas Parkway
Plano, Texas 75093
1-800-FASTNET
Phone: + 1.214.654.5000
Fax: + 1.214.654.5500

About Interphase Corporation

Interphase Corporation (NASDAQ: INPH) delivers solutions for LTE and WiMAX, interworking gateways, packet processing, network connectivity, and security for key applications for the Communications, Aerospace-Defense, and Enterprise markets. Founded in 1974, Interphase provides expert Engineering Design and Contract Manufacturing services, in addition to its COTS portfolio, and plays a leadership role in next generation AdvancedTCA® (ATCA), AdvancedMC™ (AMC), PCI-X, and PCIe standards and solutions.